

INTERNATIONAL® eMV™ SERIES TRUCK COMPLETE SERVICE CONTRACT



eMV™ Series



Full planned maintenance coverage, including high-voltage components, wear components and chassis



Proactive service communication and planned maintenance scheduling



Work performed by highly skilled technicians trained on our electric vehicle powertrain



Zero-deductible extended service contract coverage with no claims maximums

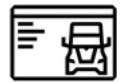

Advanced remote diagnostics and EV analytics reports

DELIVERING CONFIDENCE. MILE AFTER MILE.

International® is a leader in helping fleets make the transition to a zero-emissions future. That's why we include International® Service Contracts for every International® eMV™ Series truck. These ownership solutions are designed to enhance productivity, efficiency, lower total cost of ownership, and most importantly, peace of mind. Backed by the industry's largest service network, International is dedicated to keeping your truck on the road mile after productive mile.

INTERNATIONAL eMV SERIES TRUCK COMPLETE SERVICE CONTRACT

PLANNED MAINTENANCE

WEAR ITEM COVERAGE

Quantity dependent on length of contract

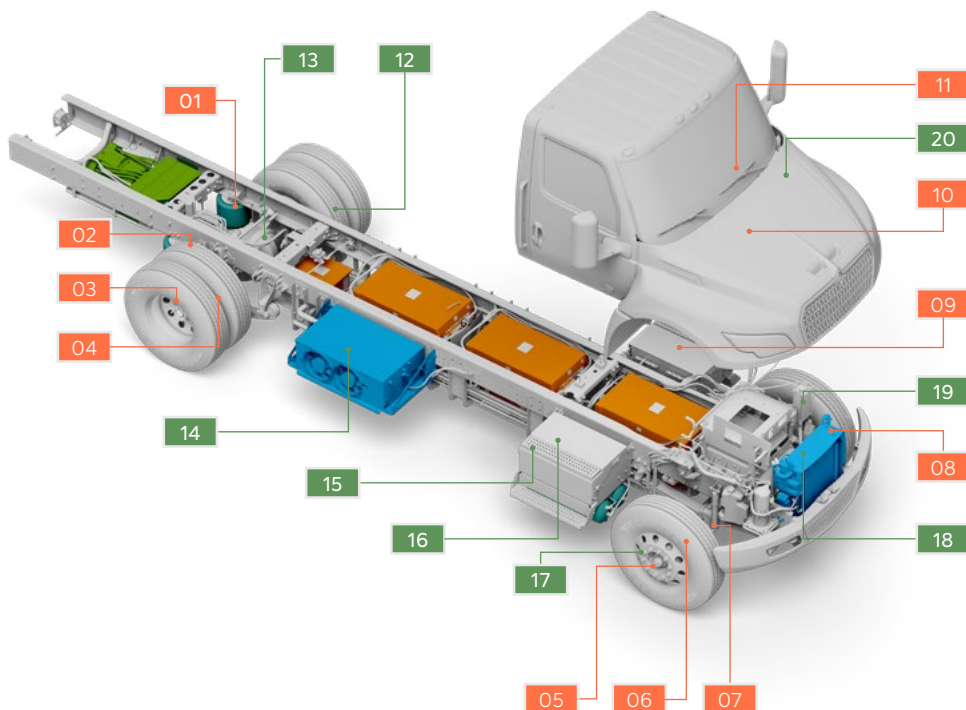

01	Rear Air Springs
02	Rear Shocks
03	Rear Wheel Seal
04	Rear Brakes
05	Front Wheel Seals
06	Front Brakes
07	Front Shocks
08	Cooling System Clamps & Hoses
09	12V AGM Battery
10	HVAC Filters
11	Wiper Blades
12	Wheel Ends
13	Rear Axle
14	High Voltage Battery Thermal Management System
15	Air Dryer
16	High Voltage Air Compressor Filter Element
17	Wheel Bearings
18	High Voltage Power Electronics Cooling System
19	Power Steering System
20	High Voltage Cabin Heater

PLANNED MAINTENANCE

Consistent, reliable, high quality work across our service network of EV authorized dealerships.

- Complete PM coverage for high voltage and chassis components
- Extensive protection coverage on wear components
- Comprehensive annual multipoint vehicle inspection

SERVICE EVENT ORCHESTRATION

Dedicated resources to managing and expediting your service and repair events including:

- Review repair history and identify open campaigns or calibration updates with the service location.
- Coordinate technical and field support and facilitate expedited parts shipments when needed
- Help facilitate timely communications and service progress updates to keep you informed

Speak with your sales representative about available coverage term options.

*Contact your International® Dealer today for more details on complete component and systems coverages. This document is a summary for reference purposes only. TAD24017 10/2024 ©2024 International Motors, LLC. All rights reserved. All marks are trademarks of their respective owners.



PROACTIVE SERVICE PLANNING

Our team will use remote vehicle health and performance data to support you in planning service events.

- You will receive communication in advance of upcoming service and maintenance needs
- We will coordinate with you to schedule service at a time and location that minimizes disruption to your operations
- This proactive approach can lead to FEWER and FASTER service events during your ownership cycle

SERVICE CONTRACT COVERAGE

- Battery coverage: high voltage battery protection to 70% state of health, workmanship and defects
- ePowertrain coverage: all high voltage powertrain components
- Chassis coverage: Same areas of coverage as diesel-powered MV series, including basic vehicle high voltage components
- Towing coverage: up to \$1,100 reimbursement per incident due to warrantable failures
- Guaranteed \$0 deductible, 100% parts and labor, and no claims maximums



**INTERNATIONAL
FINANCIAL**

These service contracts are available at no financing cost. Ask your dealer about a payment program through International® Financial.